

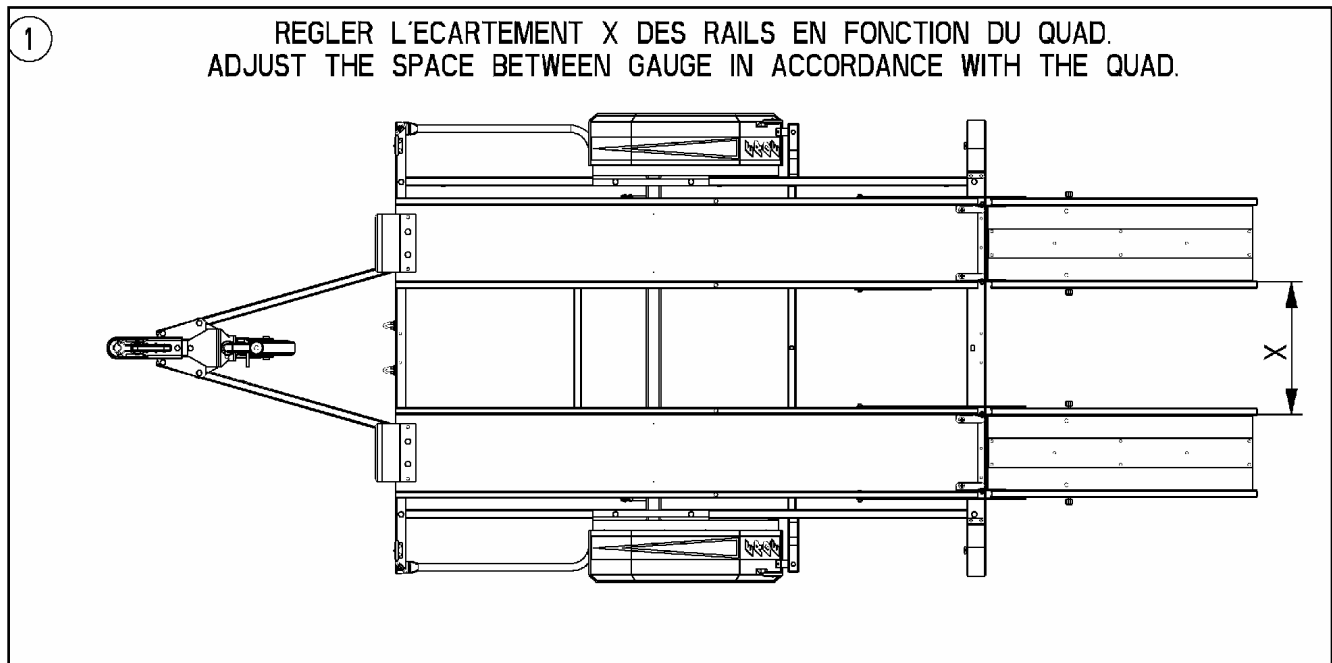



**NOTICE DE MONTAGE ET D'UTILISATION  
ASSEMBLY AND USAGE INSTRUCTIONS  
REF : PKPQ 000**



**PACK RAIL PORTE QUAD : - Modèles CH 451 et CH 751  
Rail pack quad carrier:- Models CH 451 and CH 751**



2

			
Qte: 2	Qte: 1	Qte: 2	Qte: 2
HM 10x25	BUTEE	PATTE AV	FR HM10

BASCULER LES TIRANTS COTE RAMPE  
POUR CHARGER LE QUAD  
TIPOVER TIE-BEAM ON THE RAMP  
SIDE TO LOAD THE QUAD

		
Qte: 2	Qte: 2	Qte: 2
8x25	PATTE AR	FR HM 8

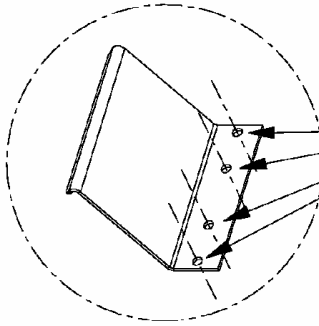
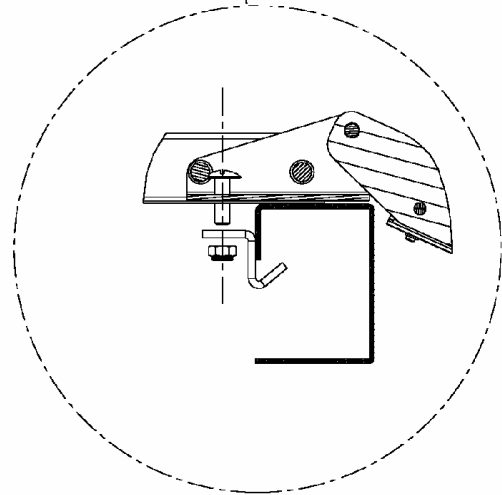
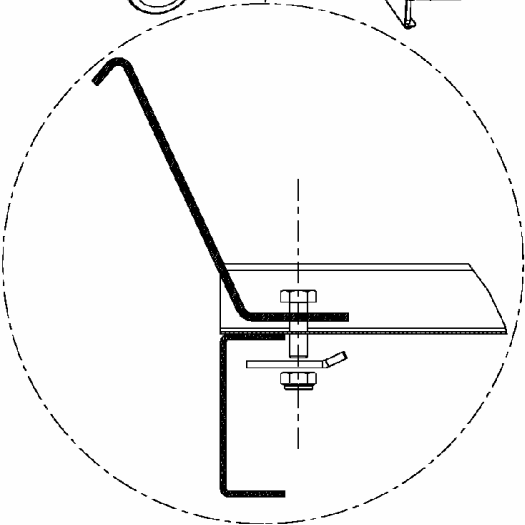
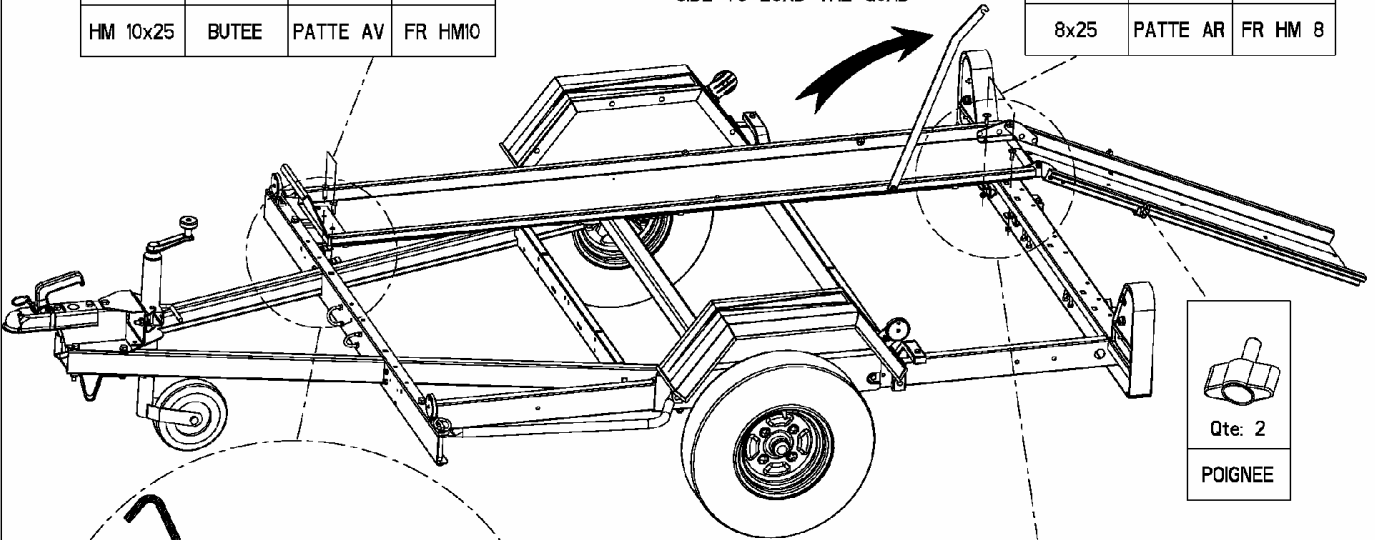

4 TROUS DISPONIBLES POUR LA FIXATION SUIVANT  
REGLAGE DE LA COTE X  
THERE ARE 4 HOLES LEFT FOR FIXING FOLLOWING  
THE ADJUSTMENT OF THE X-SIDE

BLOQUER LES FIXATIONS  
BLOCK ALL BINDINGS

POSITION DES RAMPES  
REMOREQUE CHARGEE AVEC QUAD.  
RAMP POSITION OF QUAD  
LOADED TRAILER.

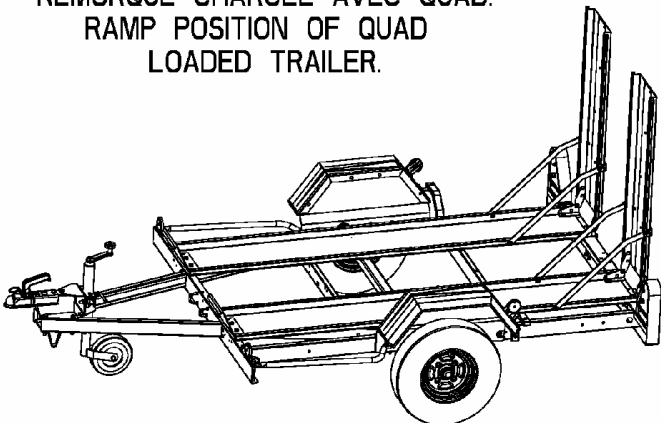

POSITION DES RAMPES REMORQUE A VIDE.  
RAMP POSITION OF UNLOADED TRAILER.

⚠ METTRE LES SANGLES  
PUT ON STAPS

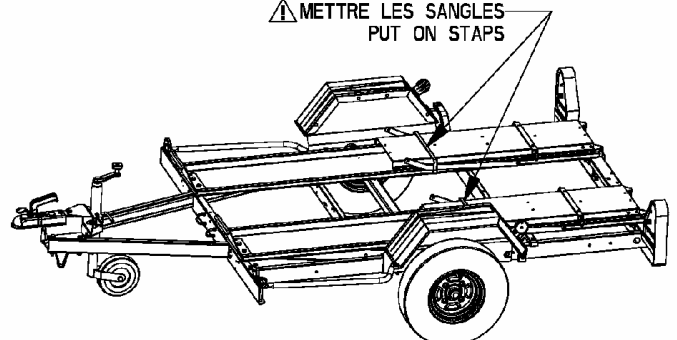

⚠ TOUJOURS METTRE LES RAMPES DANS  
CETTE POSITION LORSQUE VOUS ROULEZ A VIDE.  
ALWAYS PUT RAMP IN THIS POSITION  
WHILE DRIVING UNLOADEN.